

The Challenge Machinery Company provides owner's manuals on its products solely as a courtesy to its customers. See the information below before using this manual.

These manuals are for reference only. These manuals include products which are noncurrent, unsupported or no longer produced by The Challenge Machinery Company, and are provided solely as an accommodation to our customers. By providing these manuals, The Challenge Machinery Company makes no representation or warranty as to the products, their current condition, or their suitability or fitness for use in any particular application, which are the sole and independent responsibility of the product owner and user.

Older products may not comply with current safety procedures, guidelines or regulations, and it is the product owner's and user's responsibility to evaluate the suitability and fitness of the products in their current use and application. The Challenge Machinery Company makes no representation, warranty or recommendation regarding any modifications which may be required on non-current or unsupported products. The Challenge Machinery Company assumes no liability for any modification or alteration to any Challenge product, and any such modification or alteration to any Challenge product is not authorized by The Challenge Machinery Company. The availability of these manuals is solely for the purpose of providing reference information for the products.

This manual may not be complete in all aspects of product maintenance and repair. **All products should be used only by qualified and properly trained personnel, following proper safety procedures.** All products should be regularly inspected and maintained, and their condition, application and use should be periodically evaluated by qualified personnel. Only qualified and properly trained technicians should perform maintenance, repair and replacement procedures. Attempting these procedures without proper training may cause machine damage or operator injury!

Products may be unsupported by The Challenge Machinery Company due to age or the unavailability of parts from their original manufacturer. No parts or product support will be available to repair or maintain unsupported products. Older products may not be UL listed (if the product does not have a UL label it is not a listed product), and may not comply with applicable installation or other regulations or requirements if relocated to a new facility. Many municipalities require a product to be UL listed before an electrician will connect power to them. Often the cost of updating an older product to comply with current safety regulations is greater than the value of the product.



The Challenge Machinery Company
6125 Norton Center Drive
Norton Shores, MI 49441-6081 USA

ChallengeMachinery.com

SPARTAN 150 SA

Operator's Manual

Serial Numbers:

**041001 through 159999,
150-A-150000 and up**

Sold and Serviced by

F.150-O
August 2015

1.0 Introduction

THIS MANUAL is designed to help you get the most from your Challenge equipment. Keep this manual in a safe, convenient place for quick reference by operators and service personnel.

▲▲ CAUTION SAFETY ALERT! This symbol means **CAUTION: Personal safety instructions!** Pay special attention to the instructions in bold type. Personal injury may result if the precautions are not read and followed.

READ THIS MANUAL BEFORE OPERATING! Follow precautions and instructions. If after reading the manual questions still remain, contact your Authorized Challenge Dealer.

Take a few minutes right now to **RECORD YOUR MACHINE SERIAL NUMBER** in the space provided on the front cover of this manual. Also be sure to fill out the warranty card accompanying your machine and return it **DIRECTLY TO CHALLENGE**.

If you bought a used machine, it is important to have the following information on record at Challenge. Copy this page, fill in the information and send it care of The Challenge Service Department, 6125 Norton Center Drive, Norton Shores MI. 49441.

CHALLENGE MODEL	SERIAL NUMBER	
ATTN	COMPANY	
ADDRESS		
CITY	STATE/PROVINCE	ZIP
PHONE	DATE INSTALLED	
DEALER NAME & CITY		

*** WARRANTY INFORMATION ***

It is very important that you read and understand the conditions outlined in the *Warranty Information Sheet* attached to the outside of the shipping container of your machine.

The *Warranty Information Sheet* must be filled out completely and returned to THE CHALLENGE MACHINERY COMPANY in order for the warranty to be issued for this machine.

Challenge® is a registered trademark of The Challenge Machinery Company • 6125 Norton Center Drive • Norton Shores MI. 49441 Copyright© 2004 by The Challenge Machinery Company. All rights reserved. Printed in the U.S.A

TABLE OF CONTENTS

1.0 Introduction	2
2.0 Safety	4
2.1 Precautions	4
2.2 Power Lockout Procedure	4
2.3 Warning Label Definitions	5
3.0 Packing List	7
4.0 Specifications	8
5.0 Installation & Setup	9
5.1 Inspecting Shipment	9
5.2 Uncrating	9
5.3 Cleaning	9
5.4 Power Hook-Up	10
5.5 Optional Stand Assembly	10
6.0 Operation	11
6.1 Power – Main Switch	11
6.2 Backgauge Control	12
6.3 Jogging Aid	13
6.4 Line Light	13
6.5 Making a Cut	14
6.6 Adjusting the Knife Depth	14
6.7 Operating Tips	15
7.0 Knife Installation/Changing	16
7.1 Knife Removal	16
7.2 Knife Installation	17
7.3 Knife Care Tips	18
7.3.1 Knife Blade Life	18
7.3.2 Cutting Stick	19
7.3.3 Bevel Angle	19
7.3.4 Helpful Suggestions	19
7.3.5 Knife Care	19
8.0 Maintenance and Troubleshooting	22
8.1 Maintenance	22
8.2 Troubleshooting	22
9.0 Footprint	23
10.0 Safety Systems Test	24

2.0 Safety

2.1 Precautions

- This machine is designed for one-person operation. Never operate the machine with more than one person.
- Safe use of this machine is the responsibility of the operator. Use good judgment and common sense when working with and around this machine.
- Read and understand all instructions thoroughly before using the machine. If questions remain, contact the dealer from which you purchased this machine. Failure to understand the operating instructions may result in personal injury.
- Only trained and authorized people should operate this machine.
- **DO NOT ALTER SAFETY GUARDS OR DEVICES.** They are for your protection. Severe personal injury may result.
- **Disconnect power** before cleaning or performing maintenance. See Section 2.2 Power Lockout Procedure.
- Observe all caution labels on this machine.
- Be sure the cutter is properly grounded.
- Be sure there is sufficient power to operate the cutter properly.
- Observe all caution plates mounted on this cutter.
- Keep foreign objects off table and away from cutter blade.
- **BE EXTREMELY CAREFUL** when handling and changing the cutter knife. Severe lacerations or dismemberment could result from careless handling procedures.
- Keep the floor around the cutter free of trim, debris, oil and grease.
- When replacing hydraulic parts, loosen the connections slowly to release pressure. Never loosen connections with the machine running.
- If the cutter sounds or operates unusually, have it checked by a qualified service person.
- **CRUSH HAZARD**, keep hand and fingers from under the clamp when clamping paper. Use Jogging Aid to load paper, and use the backgauge to push paper out before unloading. **DO NOT REACH UNDER THE KNIFE AND CLAMP AREA!**

2.2 Power Lockout Procedure

For maximum safety while making adjustments or repairs to your machine, be sure to disconnect power to the machine. Disconnect the power plug from its socket (Plug maybe of different configuration depending on country)

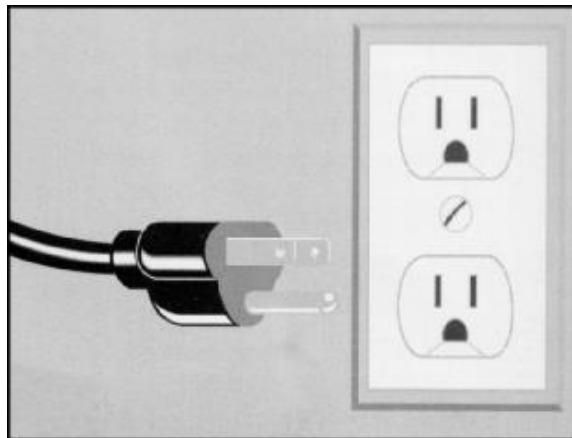

Figure 1 - Main Power Disconnect

2.3 Warning Label Definitions

The following warning labels are found at various locations on your machine. Read and understand the meaning of each symbol. If a label is lost from the machine, it should be replaced.



HAZARDOUS AREA

Disconnect power before cleaning, servicing, or making adjustments not requiring power. Do not alter safety guards or devices; they are for your protection. Replace all guards. Do not operate with any guards removed.



SHOCK HAZARD

Disconnect power before removing cover. Replace cover before operation.



SHOCK HAZARD

Disconnect power before removing cover. Replace cover before operation.



SINGLE OPERATOR

Do not operate with more than one person.

!OJO!

CAUTION

This Este simbolo de alerta de seguridad significa ¡ OJO ! - INSTRUCCIONES DE SEGURIDAD PERSONAL. Lea las instrucciones porque se refieren a su seguridad personal. Fall de obedecer las instrucciones que siguen podria resultar en lesiones corporales.

- Esta maquina, junto con sus mecanismos de seguridad, esta disenada para ser manejada por
- **UNA SOLA PERSONA** a la vez. Jamas debe ser manejada por mas de una persona al mismo tiempo.
- La seguridad es la responsabilidad del operario que usa esta maquina.
- **LEA DETENIDAMENTE** el manual de instrucciones y las **PRECAUCIONES DE SEGURIDAD** antes de poner a funcionar la cortadora. Pidale a su supervisor una copia.
- El manejo de la guillotina debe estar exclusivamente a cargo de personal entrenado y autorizado para ello.
- **NO MODIFIQUE LOS MECANISMOS DE SEGURIDAD**, estan ahi para su proteccion no deben ni modificarse ni quitarse.
- **DESCONECTE LA CORRIENTE ELECTRICA** antes de proceder a hacerle servicio de limpieza, engrasar, o de hacer ajustes que no requieren corriente. Trabe el interruptor en la posicion **OFF** (apagado); vea "Procedimiento para cortar la corriente electrica" al pie de esta pagina.
- Eche llave a la guillotina y quite la llave cuando la maquina no esta en operacion; vea "Corriente electrica".
- Asegurese de que la guillotina este debidamente a tierra. Vea "Conexion de la fuerza electrica".
- Verifique el voltaje y asegurese de que este sea suficiente para el debido funcionamiento de la guillotina.
- Preste atencion a todas las placas con advertencias instaladas en esta guillotina.
- No permita que objetos estranos esten en la mesa o cerca de la cuchilla cortadora.
- **TENGA SUMO CUIDADO** al tocar y cambiar la cuchilla. Heridas severas y hasta desmembramiento pueden resultar del manejo sin cuidado o negligente.
- El suelo alrededor de la guillotina debe mantenerse despejado y libre de recortes, desperdicios, aceite y grasa.
- Al haber la necesidad de reemplazar partes hidraulicas, afloje todas las conexiones poco a poco para dejar escapar la presion. Jamas debe aflojarse conexiones mientras la maquina este andando.
- Si la guillotina empezara a sonar o trabajar diferentemente a lo acostumbrado, desconectela y consulte la seccion "Troubleshooting" (Reparador) de este manual. Si no es posible corregir el problema, llame a su servicio autorizado para que le examinen la maquina.
- **PELIGRO DE MACHUQUE** - Mantenga manos y dedos fuera de la agarradera mientras sujeta el papel. Use el calibrador trasero y su rueda de mano para empujar el papel cortado. **NO PONGA SUS MANOS BAJOLA CUCHILLA O AREA DE LA AGARRADERA.**
- **NO OPERE SIN LAS GUARDAS PROTECTORAS!**

¡ OJO ! PRECAUCION - Como proceder para desconectar la corriente electrica.

Para maxima seguridad durante ajustes y reparaciones de su maquina, verifique bien que el interruptor principal de control de corriente al cual la maquina esta conectada, este desconectado. El interruptor deba ser puesto en la posicion "OFF" (desconectado) y se debe poner un candado en la anilla. La llave del candado debe ser guardada por la persona que estara efectuando los trabajos de servicio o de reparacion en la guillotina.

Desconecte la corriente electrica antes de proceder a hacer cualquier ajuste o reparacion o de efectuar el engrase en cualquier maquina.

3.0 Packing List



Part No.	Description	Qty.
Spartan 150 SA	15" Semi Automatic Paper Cutter	1
5064	Cutting Stick Puller	1
60011	Knife – Standard (installed in machine)	1
60057	Cutting Stick	1
60058	Jogging Aid	1
60061	Knife Lifter Assembly	1
F.150-O	Operator Manual	1
W-189	5/32" Hex 'T' Allen Wrench	1

Optional Items

Part No.	Description	Qty.
60065	Floor Stand	1
60057	Extra Cutting Sticks	1
60011	Knife – Standard	1
60011-1	Knife – Long Lasting H.S.S.	1

4.0 Specifications

Description	Inch Units	Metric Units
Cutting Width	15-3/4"	40 cm
Minimum Cut	1-15/16"	4.9 cm
Clamp Opening	1-1/2"	3.8 cm
Table Space		
Front:	9"	22.9 cm
Back:	15-1/4"	38.7 cm
Dimensions		
Overall Height	19"	48.3 cm
Overall Height with Optional Stand	46"	117 cm
Table Height with Optional Stand	36"	91.4 cm
Overall Length	31"	78.7 cm
Overall Width	25-3/4"	65.4 cm
Approx. Net Weight	170 lbs	77 kg
Approx. Shipping Weight	200 lbs	91 kg
Approx. Weight of Optional Stand	40 lbs	18 kg
Electrical		
120 Volts 60 HZ. 8 Amps, Service Size 15 Amps Receptacle NEMA 5-15R Option – 220 Volts 50 Hz 4 Amps		
Sound Emission		
A-weighted sound pressure level measured in an enclosed room at operator level (6 feet/183 cm): Machine cutting a full lift of paper: 78 dB or less		

Challenge reserves the right to make changes to any product or specification without notice and without incurring responsibility to existing units.

5.0 Installation & Setup

5.1 Inspecting Shipment

This machine has been carefully packed to prevent damage during shipment. However, claims for damage or loss are the responsibility of the recipient. Inspect all shipments as soon as they are received. If there is any noticeable damage, note it on the freight bill. Visual and/or hidden damage must be reported to the claims department of the carrier within 15 days. Contact your dealer if you need any assistance. Check the contents of the box against the packing list on page 7. Make sure there are no missing items.

5.2 Uncrating

The Spartan 150 SA weighs approximately 200 lbs (91 kg). DO NOT risk personal injury or damage by attempting to move machinery with makeshift equipment or inadequate help. This machine is shipped on a wooden skid and enclosed in a protective, wooden frame and corrugated carton. Remove the carton by removing the nails or staples holding it to the wooden frame and lift it straight up over the cutter. Remove the wooden uprights and cut the plastic straps. Carefully lift machine off skid and set on to work surface or optional stand. Place accessories in position as shown in Figure 2 below:

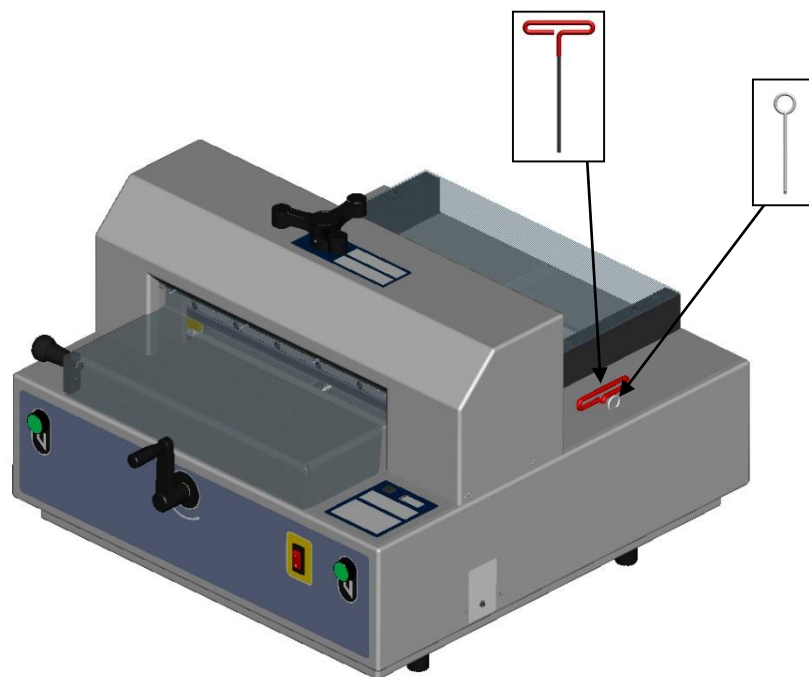

Figure 2

5.3 Cleaning

After unpacking, wipe down all machine panels and surfaces with a clean cloth.

5.4 Power Hook-Up

▲▲ CAUTION **SHOCK HAZARD! NEVER CUT THE GROUND TERMINAL** from a three-prong plug to fit a two-prong socket. Possible shock could cause personal injury or death. Have a qualified electrician provide a power source that meets electrical requirements and all local electrical codes.

It is the customer's responsibility to provide a properly grounded receptacle that meets the power requirements specified on the nameplate of this machine, as well as all local electrical codes. Have a qualified electrician install one if your location is not so equipped. The socket-outlet shall be installed near the machine's location and be easily accessible.

Connect the power cord into a grounded, 3-prong receptacle only! 120 Volts 60 HZ. 8 Amps, Service Size 15 Amps Receptacle NEMA 5-15R (Optional – 220 Volts 50HZ 4 Amp – plug maybe a different configuration depending on country)

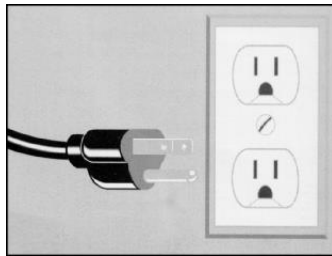

Figure 3

5.5 Optional Stand Assembly

Using two or more people, carefully set the Spartan 150 SA onto the stand assembly, inserting the four corners of the machine into the four uprights of the stand (Figure 4). Attach the machine to the stand using the screws provided with the stand.

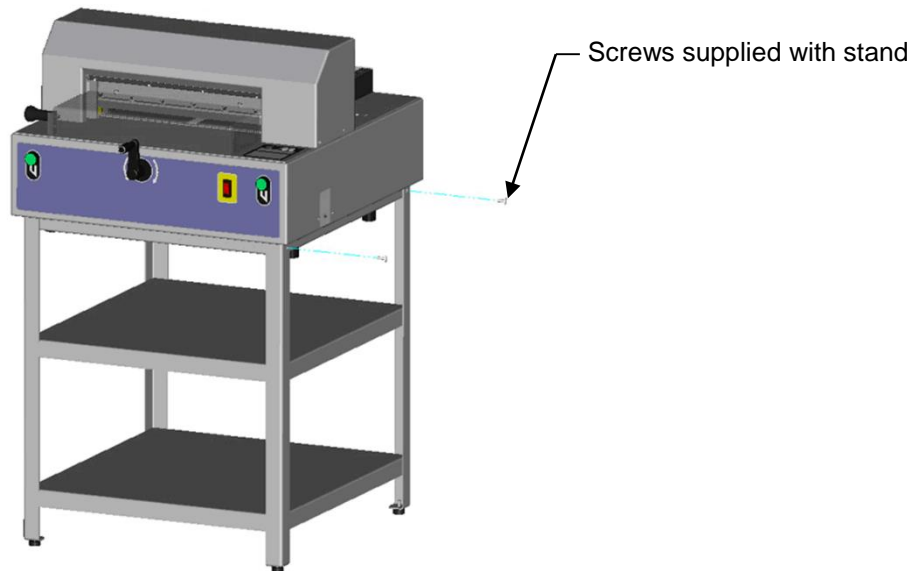

Figure 4

6.0 Operation

▲▲ CAUTION

IMPORTANT: DO NOT ATTEMPT TO OPERATE THE CUTTER UNTIL YOU HAVE THOROUGHLY READ AND UNDERSTAND ALL OF THE FOLLOWING INSTRUCTIONS. CALL YOUR AUTHORIZED CHALLENGE DEALER IF YOU STILL HAVE ANY QUESTIONS.

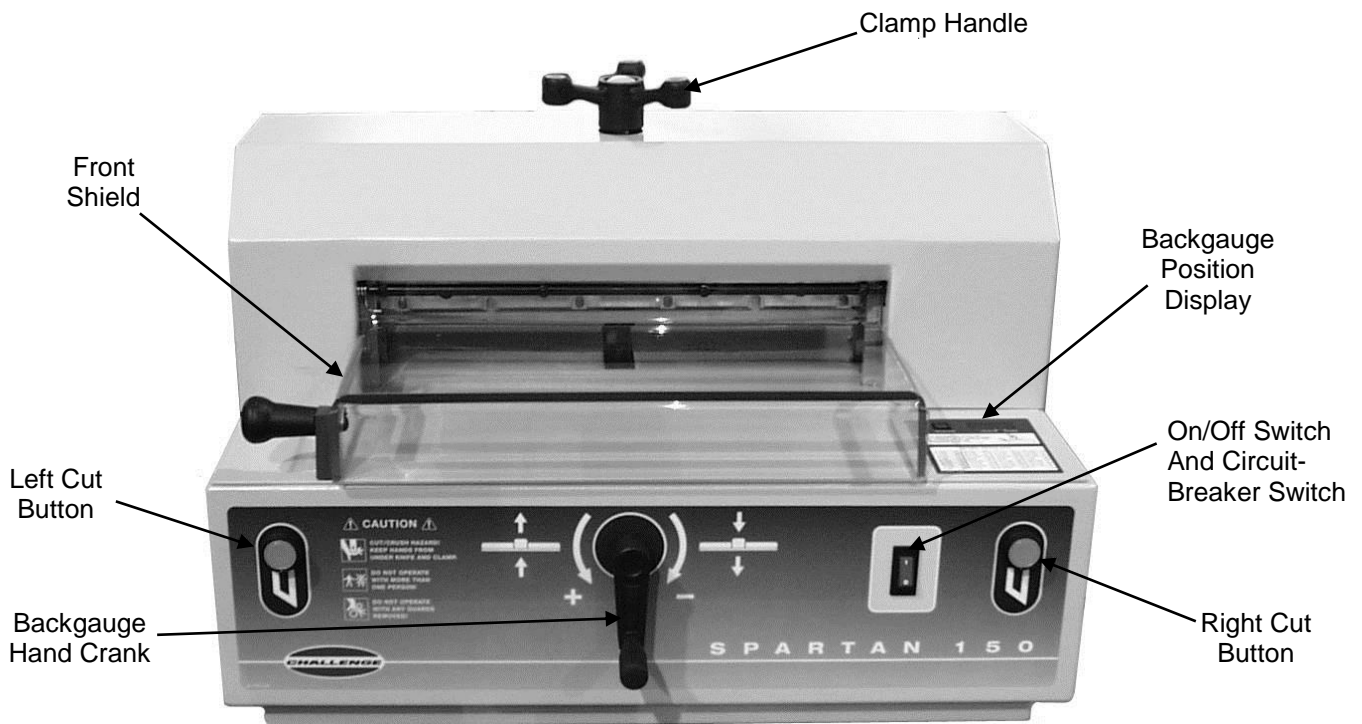

Figure 5 – Machine Controls

6.1 Power – Main Switch

Power is enabled when the main power switch is turned to the “ON” position (Figure 6). The display and line light are turned on at this time.

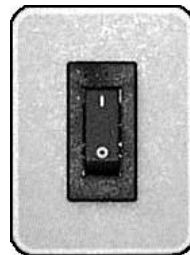

Figure 6 –Power On-Off Switch and Circuit Breaker

CAUTION

If the knife is not at the “up” position when the main power switch is turned on, the knife will automatically move to the “up” position.

The main power switch is also an 8 Amp circuit breaker and will automatically switch off in the event of too much current running through the switch, such as from an electrical short.

6.2 Backgauge Control

The backgauge is used to position paper to the desired location when cutting. The backgauge is operated by the hand crank at the front of the machine. The backgauge position is shown by a lighted LED display. When the machine is first powered up, the display shows four lines as follows, indicating the display needs to be reset.

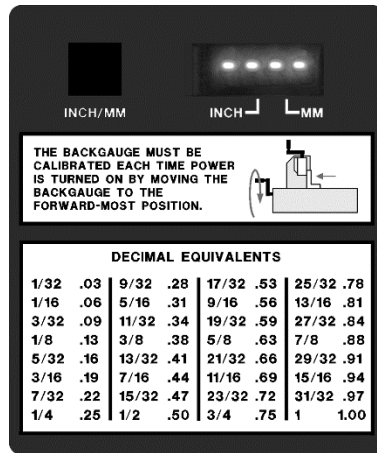

Figure 7 – Display at power up

To reset the display, bring the backgauge to the forward most position. If the backgauge is already at the forward most position, move the backgauge back by a few turns, then bring it forward again. Now the display should show the actual position of the backgauge (Figure 8). The position of the decimal point indicates whether the reading is in inches or millimeters. Two digits to the right of decimal indicates inches, one digit to the right of decimal indicates millimeters. To switch from inches to mm and vice versa, press the inch/mm button located next to the display.

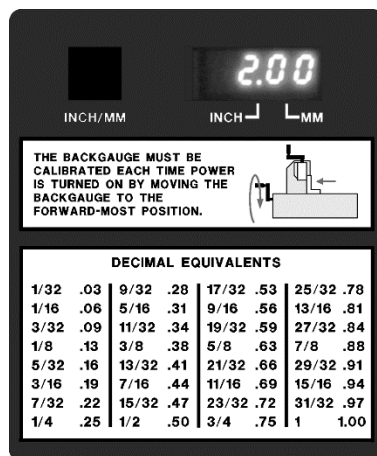

Figure 8 – Display with backgauge at 2.00 inches

6.3 Jogging Aid

▲▲ CAUTION

Always remove the jogging aid from the table before making a cut.

A jogging aid is included as standard equipment with the Spartan 150 SA. This tool allows the operator to load and align paper without the need to place hands or arms under the knife or clamp.

To use, load the paper against the side and backgauge using the jogging aid (Figure 9 & Figure 10). Remove the jogging aid from the table, close the shield, clamp the paper, and make the cut.



Figure 9

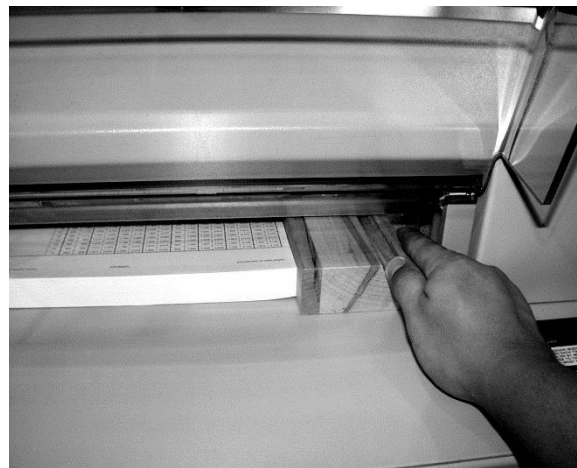

Figure 10

6.4 Line Light

The Spartan 150 SA comes standard with an LED line light. The line light comes on and stays on whenever the power is on. To use, simply align paper under clamp, and use the red light line as an indicator of where the cut will be made (Figure 11, page 14).



Figure 11 – Line Light

6.5 Making a Cut

Open the front shield and set the backgauge to the desired position. Place the paper square against the backgauge and either side guide. Clamp down on the paper using the clamp hand wheel located on top of the machine. Now close the front shield then press and hold both cut buttons (located on the front face of the machine). Hold the buttons in until the knife reaches the table. Now release the cut buttons and the knife will return to the “up” position and the front shield will automatically open. Note: releasing the cut buttons or raising the shield at any time during the cut cycle will immediately send the knife to the “up” position. Raise the clamp by turning the hand wheel and remove the cut pieces of paper.

Note: The shield must be opened and closed each time a new cut is to be made.

See Section 6.7 Operating Tips, page 15 for more information about clamping and cutting.

6.6 Adjusting the Knife Depth

The depth of cut can be adjusted using the knife depth adjusting screw located on the right side of the machine. The same T-handled wrench used for changing the knife can be used to adjust the screw. Turn the screw clockwise to increase knife depth, and counterclockwise to decrease knife depth. It is better to make several slight adjustments and perform test cuts in between, than to make large adjustments and cut too deep. Try to avoid setting the knife too deep as this can cause premature wear on knife and/or damage the cut stick.

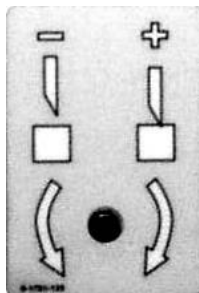

Figure 12 – Knife Depth Adjustment

6.7 Operating Tips

- Correct clamping pressure is important for getting good results. Insufficient clamping pressure may result in “draw”, where the top sheets are longer than the rest of the pile because they are drawn out from under the clamp during cutting. Excessive clamping pressure, however, may cause pile distortion and inaccurate cuts.
- For best results, you **MUST** have a sharp blade in the cutter. A dull blade will pull or draw the paper and cause uneven cutting. Increased clamp pressure will not eliminate draw caused by a dull knife.
- Carefully lay out each sheet before you start cutting. Find the best cut pattern to give you the most pieces out of the sheet. If the sheet will be folded, be sure grain of the paper is running in the same direction as the fold or you will get a rough edge on the fold.
- Mark the gripper edge and the guide edge of printed paper and make sure the first cuts are with these guide edges against the backgauge.
- When cutting business cards or narrow strips of paper, place lifts of equal height on opposite sides of the table to provide better clamping.

7.0 Knife Installation/Changing

▲▲ CAUTION

Changing knives can be very dangerous unless safety precautions are observed and extreme care is taken when handling knives.

- Make sure knife lifters are used properly, see instructions following.
- Keep handling of unprotected knives to an absolute minimum.
- Clear off cutter table before removing knife.
- Have scabbard nearby and insert knife immediately.
- Warn people of any unprotected knife.
- Knife changing is a **ONE PERSON OPERATION**. Having more than one person trying to change knives invites accidents.

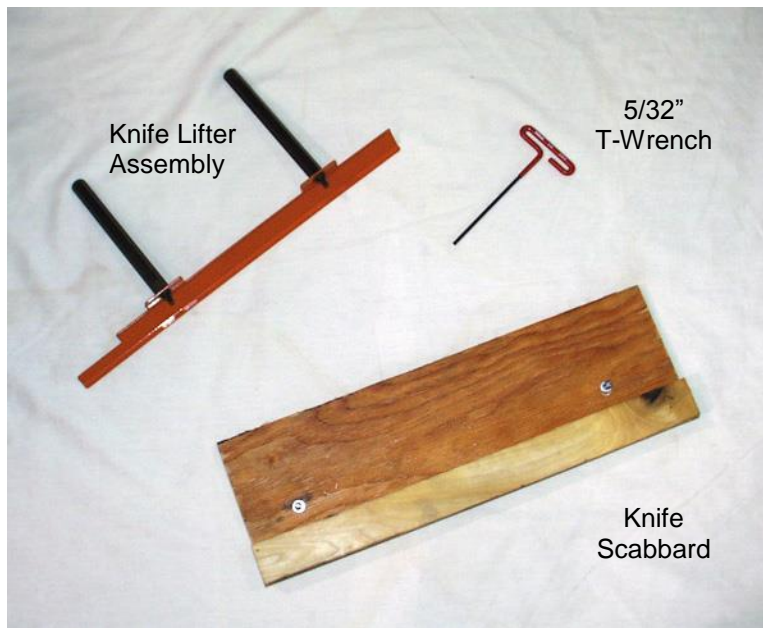

Figure 13 – Spartan 150 Knife Change Accessories

The knife changing equipment shown in Figure 13 is included with the machine. The following instructions show how to remove and install a new or re-sharpened knife. Read through these instructions **AT LEAST ONCE** before attempting to actually change or install any blades.

7.1 Knife Removal

1. Make sure the knife and clamp are in the “up” position. Turn the main power switch off and disconnect the machine power cord to prevent accidental power-up while servicing the cutter.
2. Raise the knife depth of cut all the way up by turning the knife adjusting screw located on the right side of the machine counterclockwise until it starts to unscrew out of the machine (see Section 6.6 , p. 14). This will ensure the new knife will not cut too deep since a new knife will cut deeper than one that has been ground several times. Failure to raise the depth could damage the new knife and/or the cutting stick.

3. Remove the two knife bolts from the slotted knife bar holes ONLY and replace with the knife lifter assembly (Figure 14). Tighten the lifters to hold the knife in place, and then remove the remaining four knife bolts.

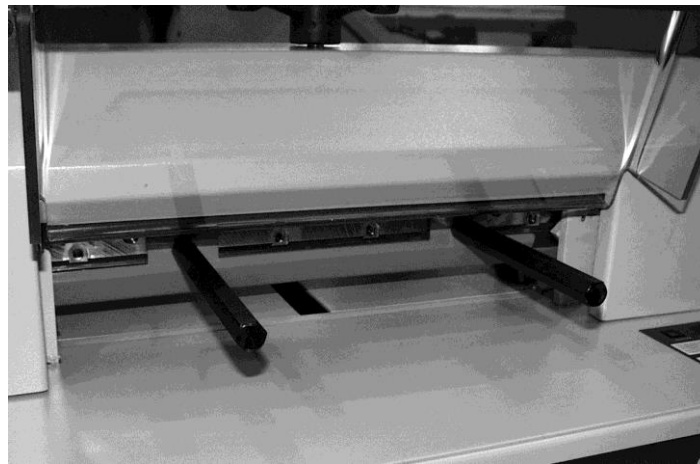

Figure 14

4. Clear the table surface and place the empty knife scabbard on a flat surface nearby. Remove the scabbard's knife retaining screws.
5. Grasp the knife lifters firmly and, at the same time, turn them counterclockwise to release the knife from the knife bar. Lower the entire assembly down, then move the knife to the left slightly then bring the knife out of the cutter, right end first. Put the blade in the scabbard immediately and secure the knife with the knife retainer screws.
6. Send dull knives to a knife grinder – do not attempt to sharpen your own knives! Knives that do not have a minimum height of 1-1/2" (3.8 cm) will not function properly and should be carefully discarded. See the Knife Care Tips Section below for additional information.

7.2 Knife Installation

▲ CAUTION

Knives are heavy and always very sharp! Be sure to keep the edge away from your body and keep other people out of the area while handling the blade. Severe lacerations or dismemberment could result from careless handling procedures.

1. Make sure the knife and clamp are in the "up" position. Turn the main power switch off and disconnect the machine power cord to prevent accidental power-up while servicing the cutter.
2. Pull out the cut stick and turn it to a new surface or replace with a new one.
3. Remove the retainer screws from the new blade and screw the knife lifters into the new blade. Screw the lifters about half way into the knife.
4. Insert the knife assembly into position under the knife bar, left end first. Raise the knife into the knife bar slot as high as it will go. Check both view holes to make sure knife is all the way up (Figure 15, page 18). Then tighten the lifters.

NOTE: If the blade will not go in, make sure the lifters are not screwed into the blade too far.

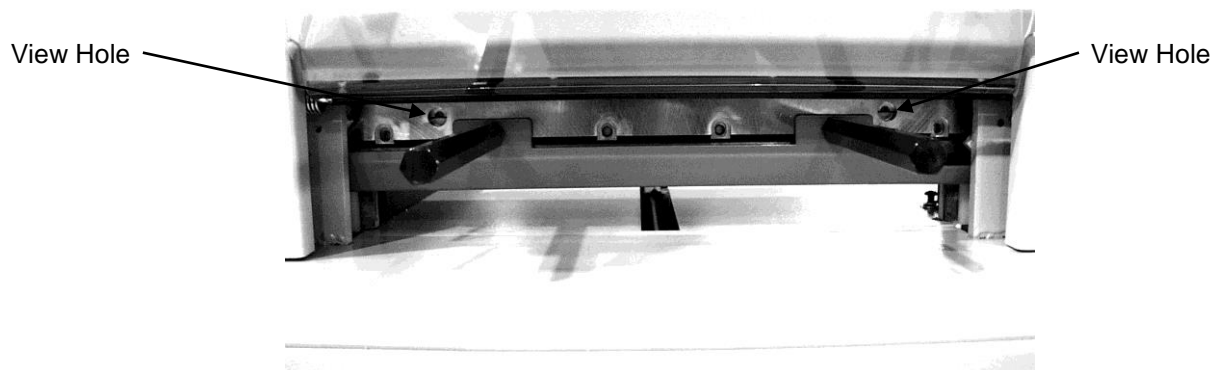

Figure 15

5. Insert and tighten four knife bolts.
6. Remove the knife lifter assembly and replace with the remaining two knife bolts.
7. Place a few sheets of paper over the cut stick, covering the stick end-to-end.
8. Clamp the paper.
9. Double check to make sure the knife depth adjusting screw has been adjusted up (step #2, Knife Removal). Plug in the power cord, turn the power on, close the shield, and press the cut buttons to perform a cut cycle.
10. If the knife does not cut all the way through (and it shouldn't on the first try), adjust the knife depth of cut by turning the adjusting screw on the right side of the machine, about one complete turn at a time to start. Continue to make cuts and adjustments until the knife cuts through all sheets. Remove paper and cut through a few larger lifts of paper to make sure the knife depth is set correctly. Adjust again if necessary.
11. Send dull knives to a knife grinder – do not attempt to sharpen your own knives! Knives that do not have a minimum height of 1-1/2" (3.8 cm) will not function properly and should be carefully discarded. See the Knife Care Tips Section below for additional information.

7.3 Knife Care Tips

▲▲ CAUTION ! **KNIFE SAFETY** ! Knives are **DANGEROUS!!!** Knives are very sharp, even after use. Keep the edge away from your body and keep the area clear of others when handling knives. Never touch the cutting edge! To prevent personal injury and damage to the knife, always keep knives in their holders with screws tightened. Even if you are aware of the dangers, others may not be. Never attempt to hone, polish, or service the knife in any way. Failure to follow safety procedures may result in severe lacerations or dismemberment.

7.3.1 Knife Blade Life

Knife blade life, or the time between sharpening, can be affected by many factors. One important factor is the type of paper being cut. Abrasive paper, such as recycled paper, soft paper such as newsprint paper, and bound books can all significantly shorten knife blade life. Also, if the knife depth is set too deep, the knife will cut too deep into the cutting stick and can quickly dull the knife blade.

A knife can last between 2,000 and 5,000 cuts before it needs to be sharpened. Cutting soft paper (such as newsprint paper) or paper with high post-consumer recycled content can cause the knife to need sharpening after only 2,000 to 3,000 cuts. Cutting pure paper, such as bond paper with no recycled content, or hard paper can allow the knife to be used for as many as 5,000 cuts before it needs to be sharpened. In all cases, the operator should continually check the quality of the cut to determine when the knife blade needs to be sharpened. Some characteristics that indicate a blade needs sharpening are:

- The knife hesitates or stalls while making a cut.
- The sheets are not all cut to the same length (usually the top few sheets are longer than the rest of the sheets - this is sometimes called “draw”).
- Cut marks appear on the cut face of the paper.
- The profile of the cut (side view) is not perpendicular to the table.
- The cut does not appear straight when viewed from the top.
- The knife makes a “rough” sound as it passes through paper.
- Nicks are visible on the cutting edge of the knife.

7.3.2 Cutting Stick

A worn cutting stick can affect the cut quality of the bottom sheets. When this happens, the cut stick can be rotated. Usually, the stick should be rotated one or two times between knife sharpening. Cut sticks have a “wavy” shape to them and when rotated must be rotated a full 180° to keep a flat side up. Each stick has 2 flat sides that can be used, after which it can be turned end to end, allowing the 2 flat sides to be used again, for a total of 4 positions per cut stick.

7.3.3 Bevel Angle

Challenge recommends that bevel angles for the Spartan 150 knives be 20°.

7.3.4 Helpful Suggestions

- It may be helpful to own a “set” of knives. A set consists of 3 knives: one in the machine, one as back up, and one at the grinder.
- If the machine seems to strain but the cut quality is still good, reduce the pile height. You may also carefully apply glycerin to the bevel when cutting hard, coated paper. Tie a cloth to the end of a stick; dip the stick in glycerin, and apply. Never apply by hand! In lieu of glycerin you may lightly rub white bar soap along the bevel. Lubrication will prolong the life of your machine and reduce maintenance.

7.3.5 Knife Care

- To prevent corrosion, knives are coated with light oil. It should be REMOVED WITH CARE.
- While removing or installing a knife, be careful not to allow the edge to bump against the machine. Nicks will result.

7.0 Knife Installation/Changing

- If a knife bolt is damaged, replace it.
- Always keep knife bolts securely tightened.
- Store knives in a dry environment to prevent corrosion.
- Never attempt to service a knife in any way.

NOTES

8.0 Maintenance and Troubleshooting

8.1 Maintenance

▲▲ CAUTION All maintenance on this machine should be performed by trained service personnel. Attempting to perform repair and replacement procedures without proper training may cause machine damage or operator injury!

8.2 Troubleshooting

Problem	Possible Cause	Solution
1. The machine will not power up – no display, no line light, and machine will not cycle.	a) Power cord is disconnected. b) Main power switch/circuit breaker is off. c) No power at electrical outlet.	a) Plug in cord. b) Turn power switch/circuit breaker on. c) Check outlet. Repair or use another outlet.
2. Display and line light are on, but machine will not cycle.	a) Front guard is open. b) Front guard has not been opened and closed since previous cut cycle.	a) Close front guard. b) Open and close front guard.
3. Backgauge display shows: “----“.	a) Backgauge has not been preset.	a) Preset Backgauge by bringing backgauge to front of machine
4. Knife cuts deeper on one side than the other.	a) Knife is not seated all the way up in knife bar.	a) Loosen knife screws and use knife lifter assembly to raise knife up tight. See Section 7.2 Knife Installation, page 17.
5. The machine strains through a cut.	a) Dull knife. b) Paper clamped too tight. c) Inadequate power source.	a) Change the knife with a new or sharpened one. See Section 7.0 Knife Installation/Changing, page 16 for instructions. b) Apply less force on clamp handle when clamping paper. c) The electrical outlet may not have sufficient power if other equipment is operating on the same line. Try another outlet on a different line.
6. Concave cutting – ends wide, center narrow.	a) Excessive moisture at edges of paper.	a) Keep paper in dry location.
7. Concave cutting – variation from top to bottom.	a) Soft paper not firmly clamped. b) Knife dull or incorrectly ground.	a) Apply more force on clamp handle when clamping. b) Change the knife with a new or sharpened one. See Section 7.0 Knife Installation/Changing, page 16 for instructions.

9.0 Footprint

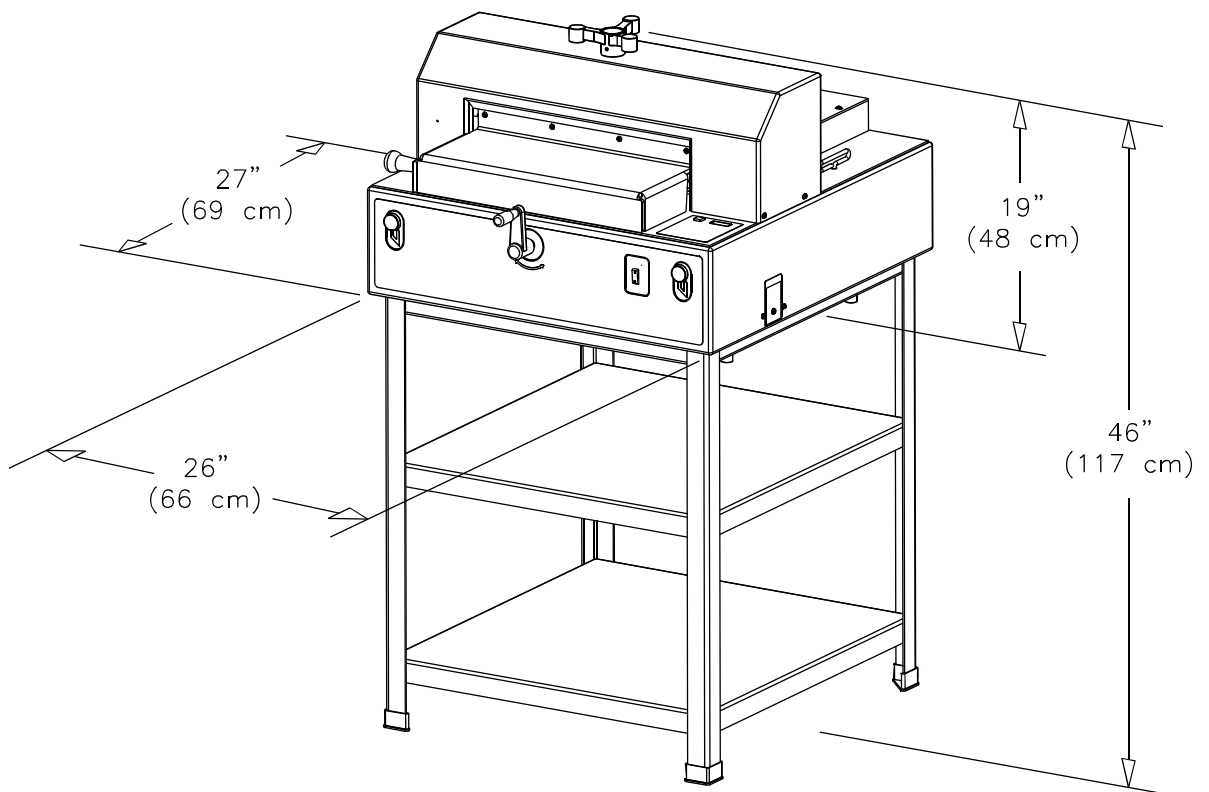

10.0 Safety Systems Test

Machine manufacturer CHALLENGE

Model SPARTAN 150 SA

Serial Number _____

Frequency of test: **THESE TESTS SHOULD BE PERFORMED AT THE BEGINNING OF EACH WORK DAY.**

Turn the power on and make sure the knife and clamp are in the up position (if they are not, follow the instructions in this manual to send them up).

Test #1: With the front shield open, press the cut buttons. Nothing should happen. If the knife comes down with the front guard open, do not use the machine. Repair or adjustment is needed.

Test #2: Close the front guard and press the cut buttons. While the knife is coming down, open the front shield. The knife should immediately return to the up position. If it does not, do not use the machine. Repair or adjustment is needed.

