

# HANDY-SHARP

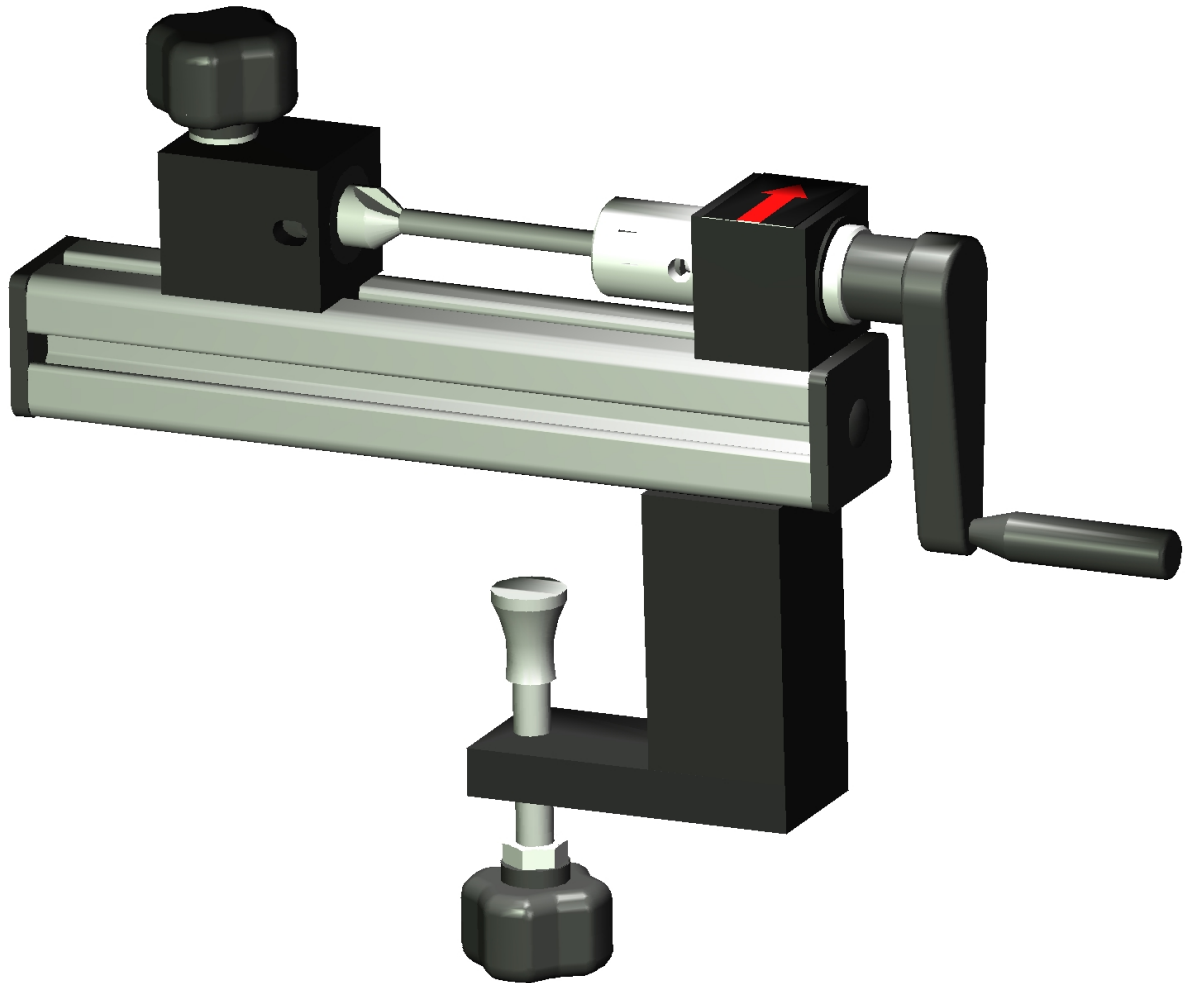

**The Challenge Machinery Company**  
6125 Norton Center Drive  
Norton Shores, MI 49441 USA  
Phone: 231.799.8484 Fax: 231.798.1275  
[www.ChallengeMachinery.com](http://www.ChallengeMachinery.com)

---

---

# HANDY-SHARP



## Features

- Spring-loaded pressure prevents flaring the end of the hollow drill bits
- Light and portable
- Clamps onto a bench or table
- Easy to use
- Repairs “far-gone” bits
- Includes a safe chip remover

## Keep your hollow drill bits sharp

Maintaining a sharp hollow drill bit has two distinct benefits. First, sharp bits increase the life of your drilling machine by reducing the force required to drill, thereby minimizing wear-and-tear on the machine. Second, dull hollow drill bits are more likely to break or flare—costing money and creating downtime.

## How Handy-Sharp works

The Handy-Sharp mounts on the edge of a table or bench. A dull hollow drill bit is placed in the holder, and the cutting bit is pushed against the end of the hollow drill bit until its spring bottoms out. The spring prevents excessive force from being applied while sharpening. Turning the handle while applying a hone produces a fine edge.

## Specifications

- Sharpens bits 1/8" to 1/2" in diameter
- Width 1-1/2"
- Depth 13-7/16"
- Height 4-5/32"
- Net weight (approx.) 8 lbs.
- Shipping weight (approx.) 9 lbs.

## Kit Includes

- Handy-Sharp Sharpener with cutter
- Safe chip remover (see below)
- Drill drift
- Drill-Ease lubricant

## Coming Soon!

- Adapters for non-Challenge hollow drills

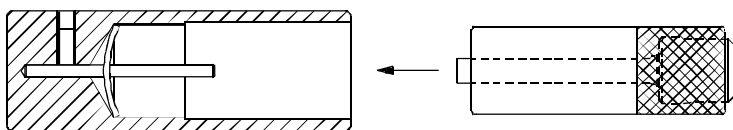
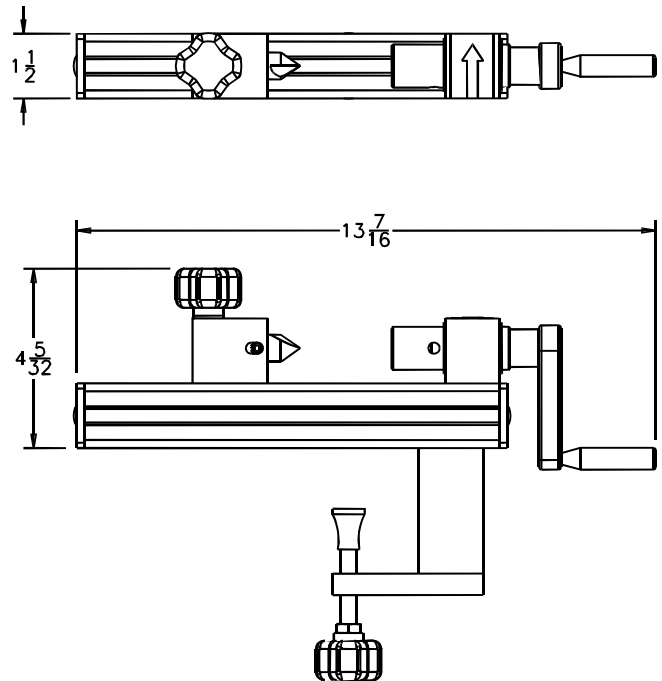

Chip Remover